

Advanced Regulating Pulse Width Modulators

FEATURES

- Complete PWM Power Control Circuitry
- Uncommitted Outputs for Single-ended or Push-pull Applications
- Low Standby Current...8mA Typical
- Interchangeable with SG1524, SG2524 and SG3524, Respectively

DESCRIPTION

The UC1524, UC2524 and UC3524 incorporate on a single monolithic chip all the functions required for the construction of regulating power supplies, inverters or switching regulators. They can also be used as the control element for high-power-output applications. The UC1524 family was designed for switching regulators of either polarity, transformer-coupled dc-to-dc converters, transformerless voltage doublers and polarity converter applications employing fixed-frequency, pulse-width modulation techniques. The dual alternating outputs allow either single-ended or push-pull applications. Each device includes an on-chip reference, error amplifier, programmable oscillator, pulse-steering flip-flop, two uncommitted output transistors, a high-gain comparator, and current-limiting and shut-down circuitry. The UC1524 is characterized for operation over the full military temperature range of -55°C to +125°C. The UC2524 and UC3524 are designed for operation from -25°C to +85°C and 0° to +70°C, respectively.

CONNECTION DIAGRAM

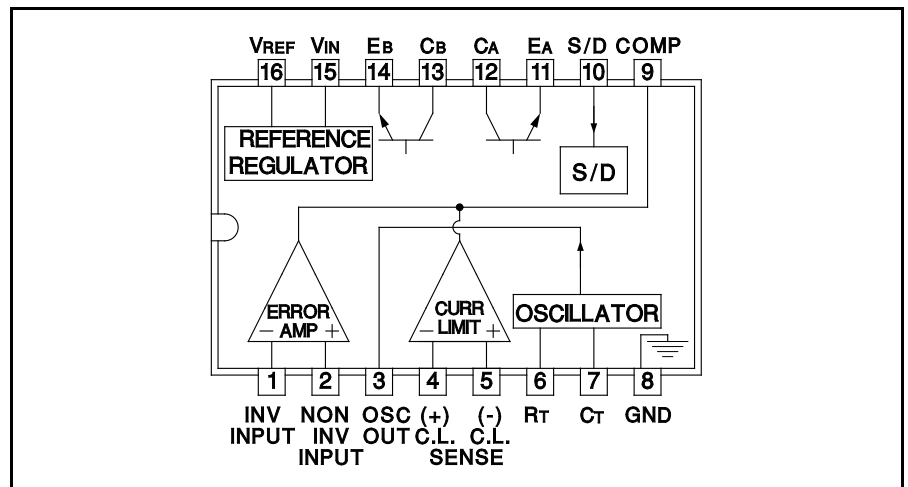

BLOCK DIAGRAM

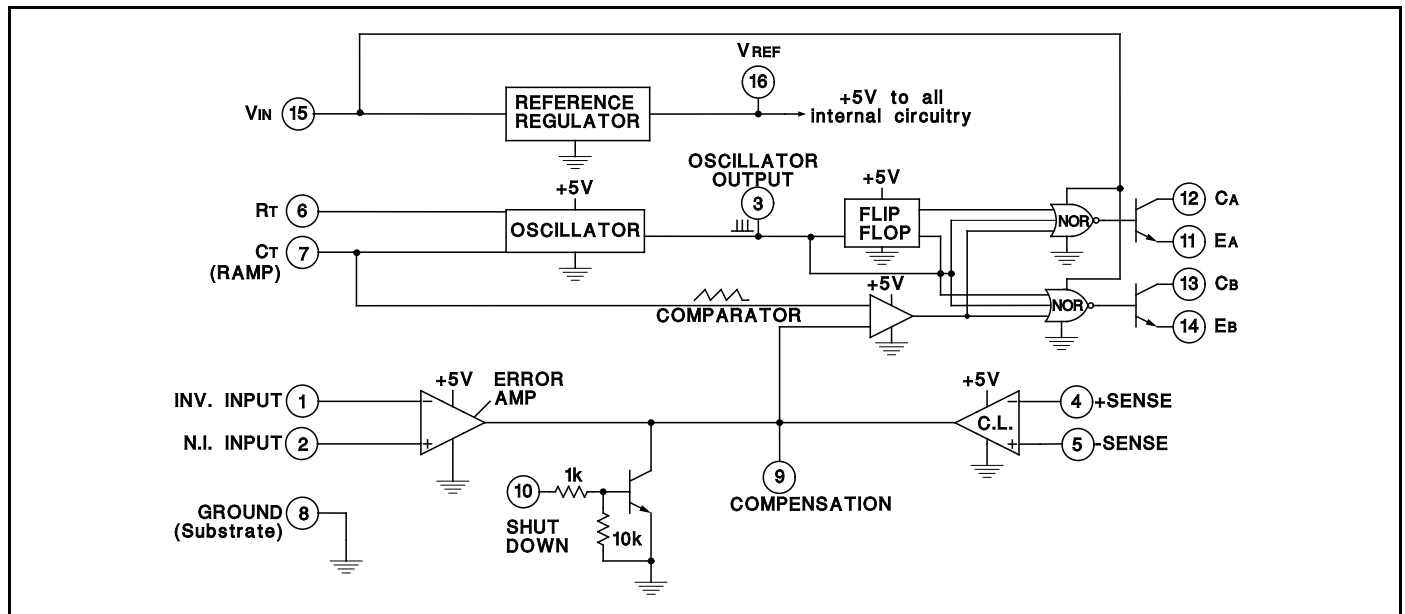

ELECTRICAL CHARACTERISTICS: Unless otherwise stated, these specifications apply for $T_A = -55^\circ\text{C}$ to $+125^\circ\text{C}$ for the UC1524, -25°C to $+85^\circ\text{C}$ for the UC2524, and 0°C to $+70^\circ\text{C}$ for the UC3524, $V_{IN} = 20\text{V}$, and $f = 20\text{kHz}$, $T_A = T_J$.

PARAMETER	TEST CONDITIONS	UC1524/UC2524			UC3524			UNITS
		MIN	TYP	MAX	MIN	TYP	MAX	
Reference Section								
Output Voltage		4.8	5.0	5.2	4.6	5.0	5.4	V
Line Regulation	$V_{IN} = 8$ to 40V		10	20		10	30	mV
Load Regulation	$I_L = 0$ to 20mA		20	50		20	50	mV
Ripple Rejection	$f = 120\text{Hz}$, $T_J = 25^\circ\text{C}$		66			66		dB
Short Circuit Current Limit	$V_{REF} = 0$, $T_J = 25^\circ\text{C}$		100			100		mA
Temperature Stability	Over Operating Temperature Range		0.3	1		0.3	1	%
Long Term Stability	$T_J = 125^\circ\text{C}$, $t = 1000$ Hrs.		20			20		mV
Oscillator Section								
Maximum Frequency	$C_T = .001\text{mfd}$, $R_T = 2\text{k}\Omega$		300			300		kHz
Initial Accuracy	R_T and C_T Constant		5			5		%
Voltage Stability	$V_{IN} = 8$ to 40V , $T_J = 25^\circ\text{C}$			1			1	%
Temperature Stability	Over Operating Temperature Range			5			5	%
Output Amplitude	Pin 3, $T_J = 25^\circ\text{C}$		3.5			3.5		V
Output Pulse Width	$C_T = .01\text{mfd}$, $T_J = 25^\circ\text{C}$		0.5			0.5		μs
Error Amplifier Section								
Input Offset Voltage	$V_{CM} = 2.5\text{V}$		0.5	5		2	10	mV
Input Bias Current	$V_{CM} = 2.5\text{V}$		2	10		2	10	μA
Open Loop Voltage Gain		72	80		60	80		dB
Common Mode Voltage	$T_J = 25^\circ\text{C}$	1.8		3.4	1.8		3.4	V
Common Mode Rejection Ratio	$T_J = 25^\circ\text{C}$		70			70		dB
Small Signal Bandwidth	$A_v = 0\text{dB}$, $T_J = 25^\circ\text{C}$		3			3		MHz
Output Voltage	$T_J = 25^\circ\text{C}$	0.5		3.8	0.5		3.8	V
Comparator Section								
Duty-Cycle	% Each Output On	0		45	0		45	%
Input Threshold	Zero Duty-Cycle		1			1		V
	Maximum Duty-Cycle		3.5			3.5		V
Input Bias Current			1			1		μA
Current Limiting Section								
Sense Voltage	Pin 9 = 2V with Error Amplifier Set for Maximum Out, $T_J = 25^\circ\text{C}$	190	200	210	180	200	220	mV
Sense Voltage T.C.			0.2			0.2		$\text{mV}/^\circ\text{C}$
Common Mode Voltage		-1		+1	-1		+1	V
Output Section (Each Output)								
Collector-Emitter Voltage		40			40			V
Collector Leakage Current	$V_{CE} = 40\text{V}$		0.1	50		0.1	50	μA
Saturation Voltage	$I_C = 50\text{mA}$		1	2		1	2	V
Emitter Output Voltage	$V_{IN} = 20\text{V}$	17	18		17	18		V
Rise Time	$R_C = 2\text{k ohm}$, $T_J = 25^\circ\text{C}$		0.2			0.2		μs
Fall Time	$R_C = 2\text{k ohm}$, $T_J = 25^\circ\text{C}$		0.1			0.1		μs
Total Standby Current	$V_{IN} = 40\text{V}$		8	10		8	10	mA
(Excluding oscillator charging current, error and current limit dividers, and with outputs open)								

ABSOLUTE MAXIMUM RATINGS (Note 1)

Supply Voltage, Vcc (Notes 2 and 3)	40V
Collector Output Current	100mA
Reference Output Current	50mA
Current Through CT Terminal	-5mA
Power Dissipation at TA = +25°C (Note 4)	1000mW
Power Dissipation at Tc = +25°C (Note 4)	2000mW
Operating Junction Temperature Range	-55°C to +150°C
Storage Temperature Range	-65°C to +150°C

Note 1: Over operating free-air temperature range unless otherwise noted.

Note 2: All voltage values are with respect to the ground terminal, pin 8.

Note 3: The reference regulator may be bypassed for operation from a fixed 5V supply by connecting the Vcc and reference output pins both to the supply voltage. In this configuration the maximum supply voltage is 6V.

Note 4: Consult packaging section of databook for thermal limitations and considerations of package.

RECOMMENDED OPERATING CONDITIONS

Supply Voltage, Vcc	8V to 40V
Reference Output Current	0 to 20mA
Current through CT Terminal	-0.03mA to -2mA
Timing Resistor, RT	1.8kΩ to 100kΩ
Timing Capacitor, CT	0.001μF to 0.1μF
Operating Ambient Temperature Range	
UC1524	-55°C to +125°C
UC2524	-25°C to +85°C
UC3524	0°C to +70°C

TYPICAL CHARACTERISTICS

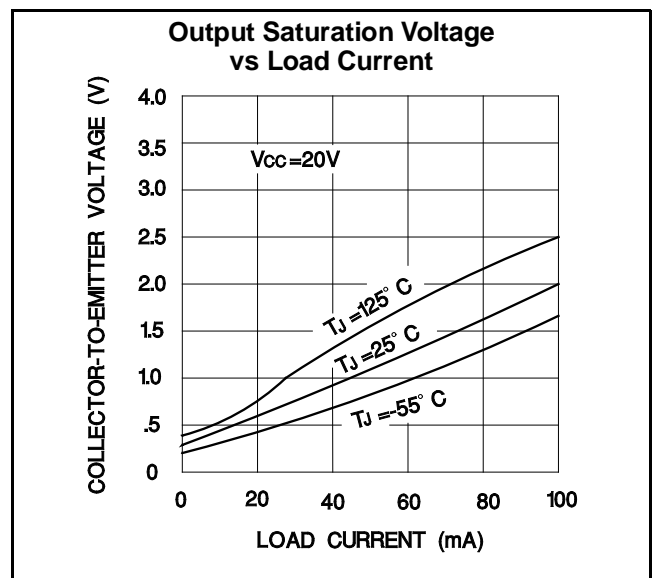
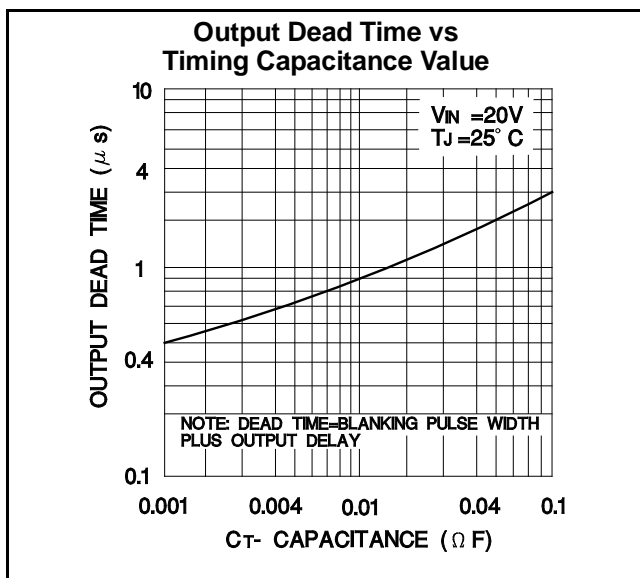
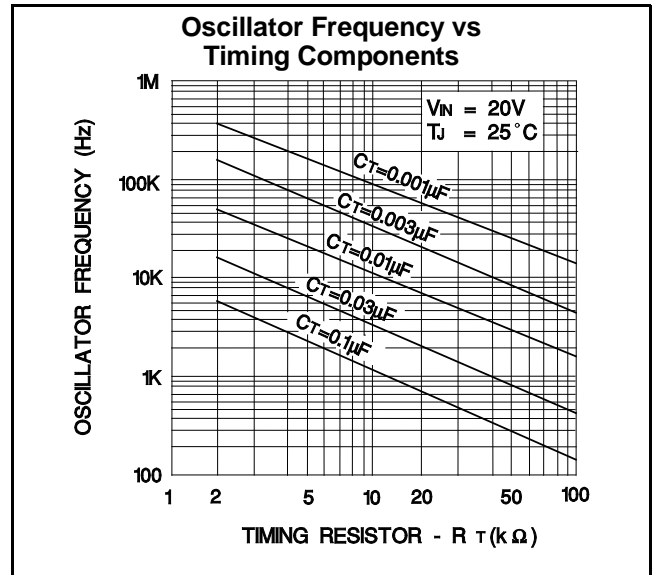
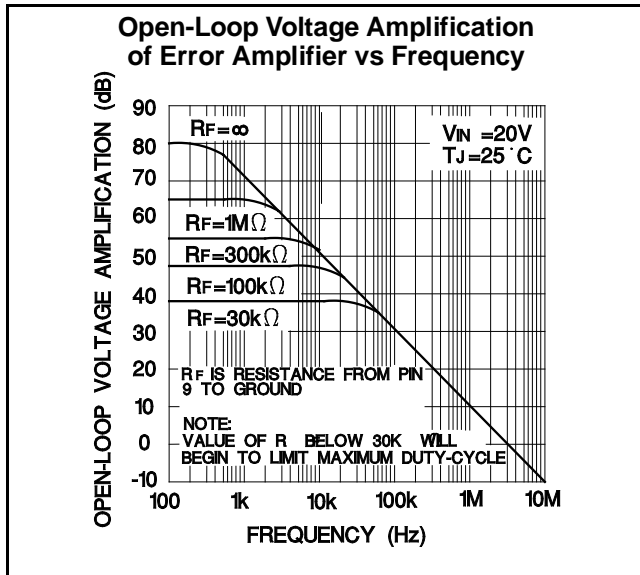

PRINCIPLES OF OPERATION

The UC1524 is a fixed-frequency pulse-width-modulation voltage regulator control circuit. The regulator operates at a frequency that is programmed by one timing resistor (R_T), and one timing capacitor (C_T), R_T establishes a constant charging current for C_T . This results in a linear voltage ramp at C_T , which is fed to the comparator providing linear control of the output pulse width by the error amplifier. The UC1524 contains an on-board 5V regulator that serves as a reference as well as powering the UC1524's internal control circuitry and is also useful in supplying external support functions. This reference voltage is lowered externally by a resistor divider to provide a reference within the common-mode range of the error amplifier or an external reference may be used. The power supply output is sensed by a second resistor divider network to generate a feedback signal to the error amplifier. The amplifier output voltage is then compared to the linear voltage ramp at C_T . The resulting modulated pulse out of the

high-gain comparator is then steered to the appropriate output pass transistor (Q_1 or Q_2) by the pulse-steering flip-flop, which is synchronously toggled by the oscillator output. The oscillator output pulse also serves as a blanking pulse to assure both outputs are never on simultaneously during the transition times. The width of the blanking pulse is controlled by the value of C_T . The outputs may be applied in a push-pull configuration in which their frequency is half that of the base oscillator, or paralleled for single-ended applications in which the frequency is equal to that of the oscillator. The output of the error amplifier shares a common input to the comparator with the current limiting and shutdown circuitry and can be overridden by signals from either of these inputs. This common point is also available externally and may be employed to control the gain of, or to compensate, the error amplifier or to provide additional control to the regulator.

TYPICAL APPLICATIONS DATA

Oscillator

The oscillator controls the frequency of the UC1524 and is programmed by R_T and C_T according to the approximate formula:

$$f \approx \frac{1.18}{R_T C_T}$$

where R_T is in kilohms
 C_T is in microfarads
 f is in kilohertz

Practical values of C_T fall between 0.001 and 0.1 microfarad. Practical values of R_T fall between 1.8 and 100 kilohms. This results in a frequency range typically from 120 hertz to 500 kilohertz.

Blanking

The output pulse of the oscillator is used as a blanking pulse at the output. This pulse width is controlled by the value of C_T . If small values of C_T are required for frequency control, the oscillator output pulse width may still be increased by applying a shunt capacitance of up to 100pF from pin 3 to ground. If still greater dead-time is required, it should be accomplished by limiting the maxi-

mum duty cycle by clamping the output of the error amplifier. This can easily be done with the circuit below:

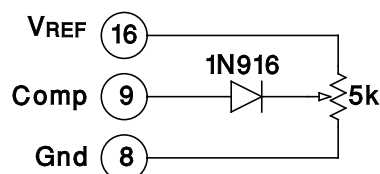

Synchronous Operation

When an external clock is desired, a clock pulse of approximately 3V can be applied directly to the oscillator output terminal. The impedance to ground at this point is approximately 2 kilohms. In this configuration R_T C_T must be selected for a clock period slightly greater than that of the external clock.

If two or more UC1524 regulators are to be operated synchronously, all oscillator output terminals should be tied together, all C_T terminals connected to single timing capacitor, and the timing resistor connected to a single R_T terminal. The other R_T terminals can be left open or shorted to V_{REF} . Minimum lead lengths should be used between the C_T terminals.

Single-Ended LC Switching Regulator Circuit

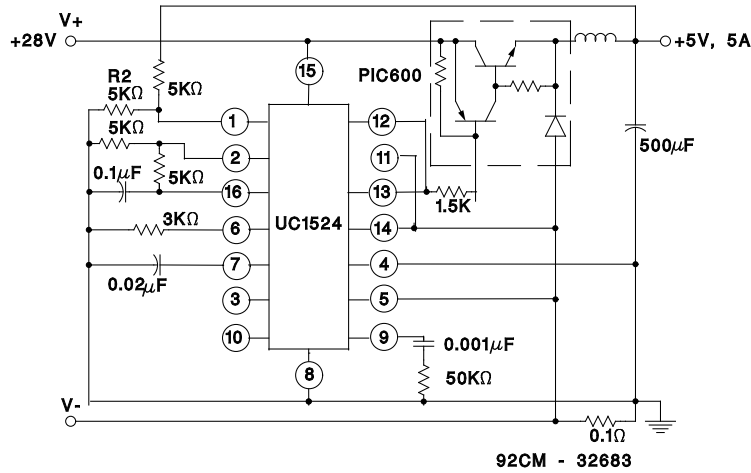

Push Pull Transformer Coupled Circuit

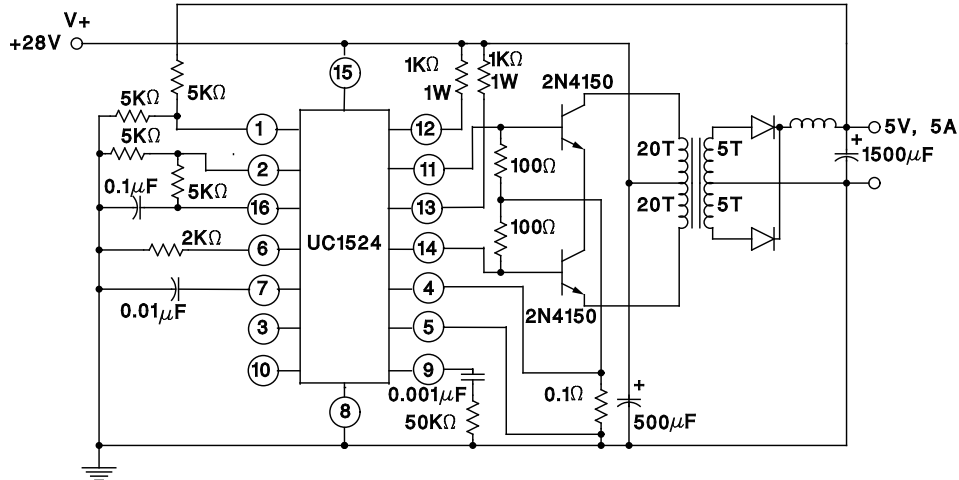

Open Loop Test Circuit

